

normet

Normet Oy
Ahmolantie 6
FI-74510 IISALMI, FINLAND
Tel +358 (0) 17 83 241
Fax +358 (0) 17 823 606
info@normet.fi www.normet.fi

Himec 9905 BT

TI 100020152
DATE 03.07.2012
PAGE 1 / 6

Twin boom platform lifter

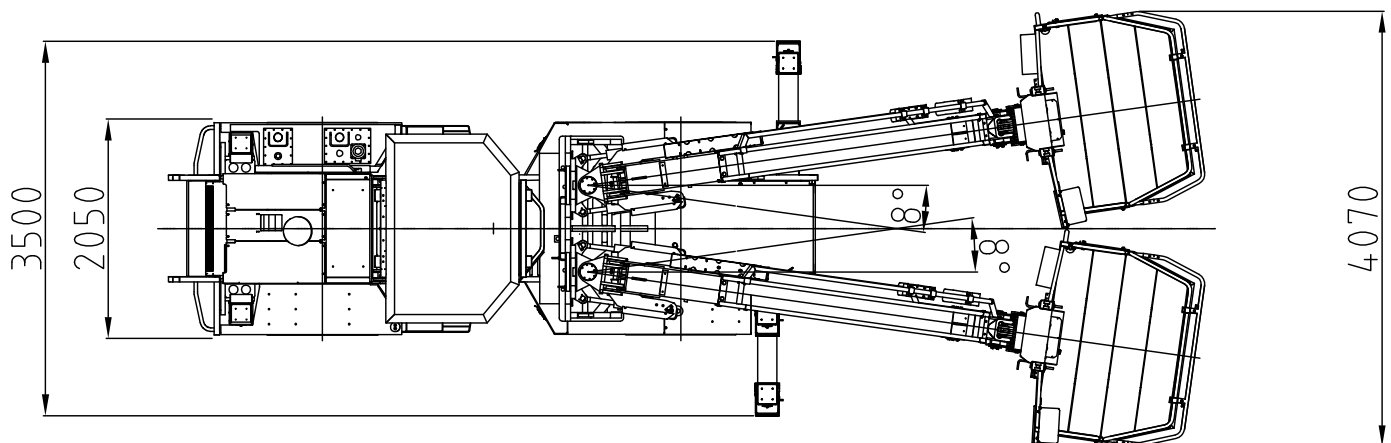
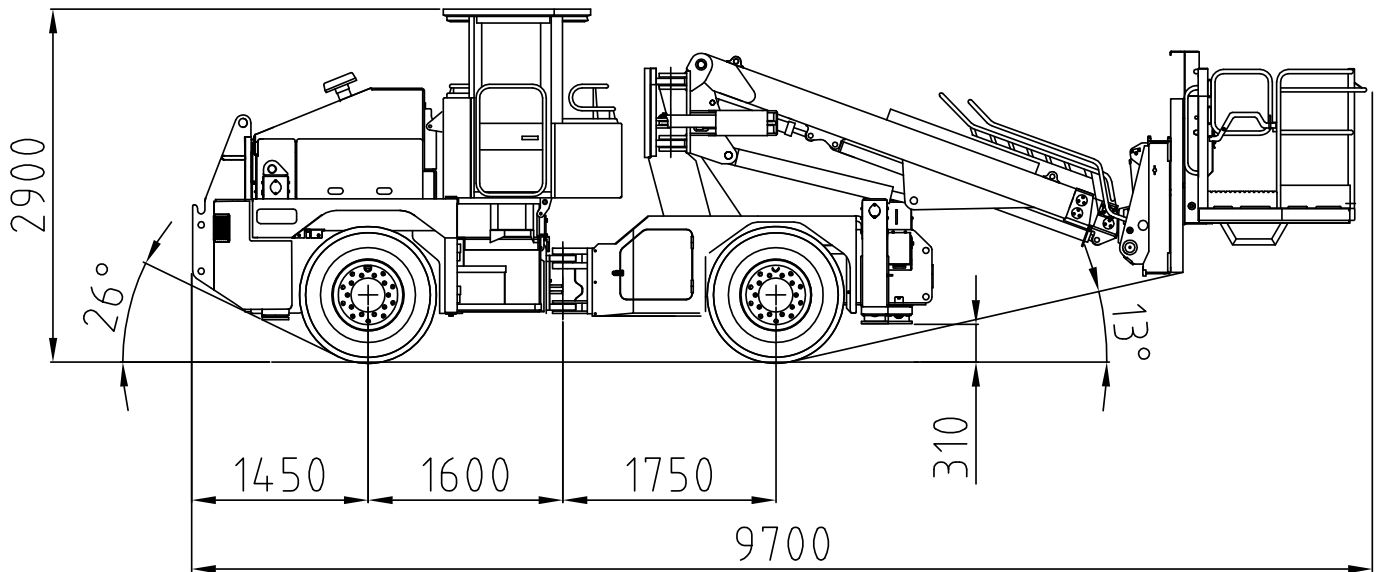

normet

Normet Oy
Ahmolantie 6
FI-74510 IISALMI, FINLAND
Tel +358 (0) 17 83 241
Fax +358 (0) 17 823 606
info@normet.fi www.normet.fi

Himec 9905 BT

TI 100020152
DATE 03.07.2012
PAGE 2 / 6

Twin boom platform lifter

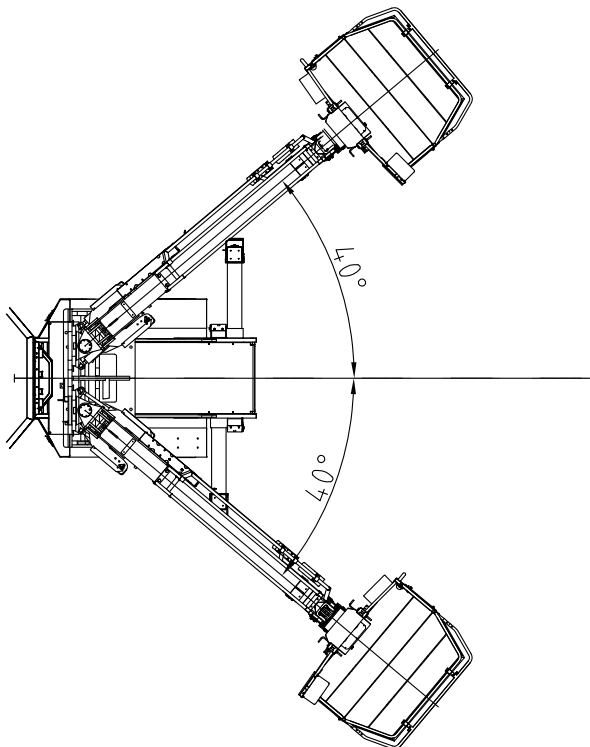
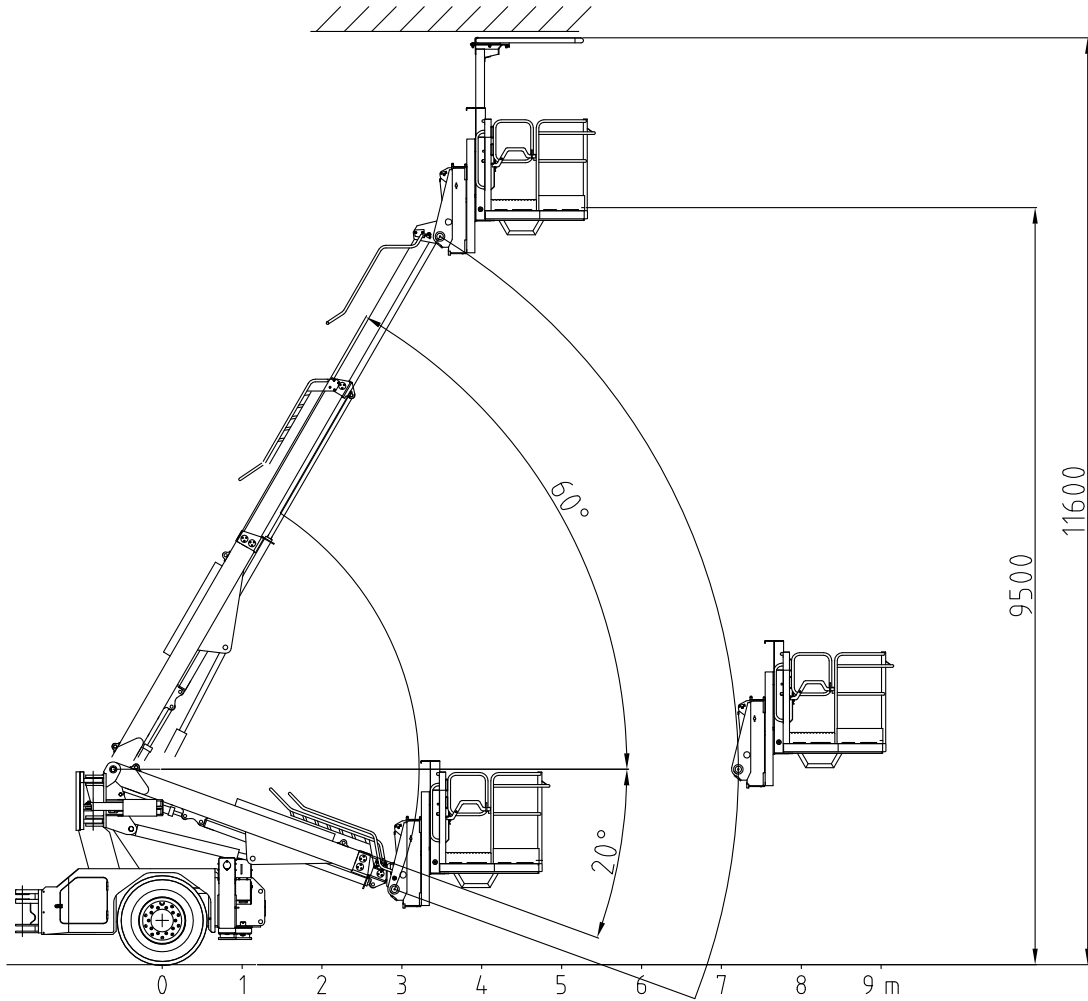

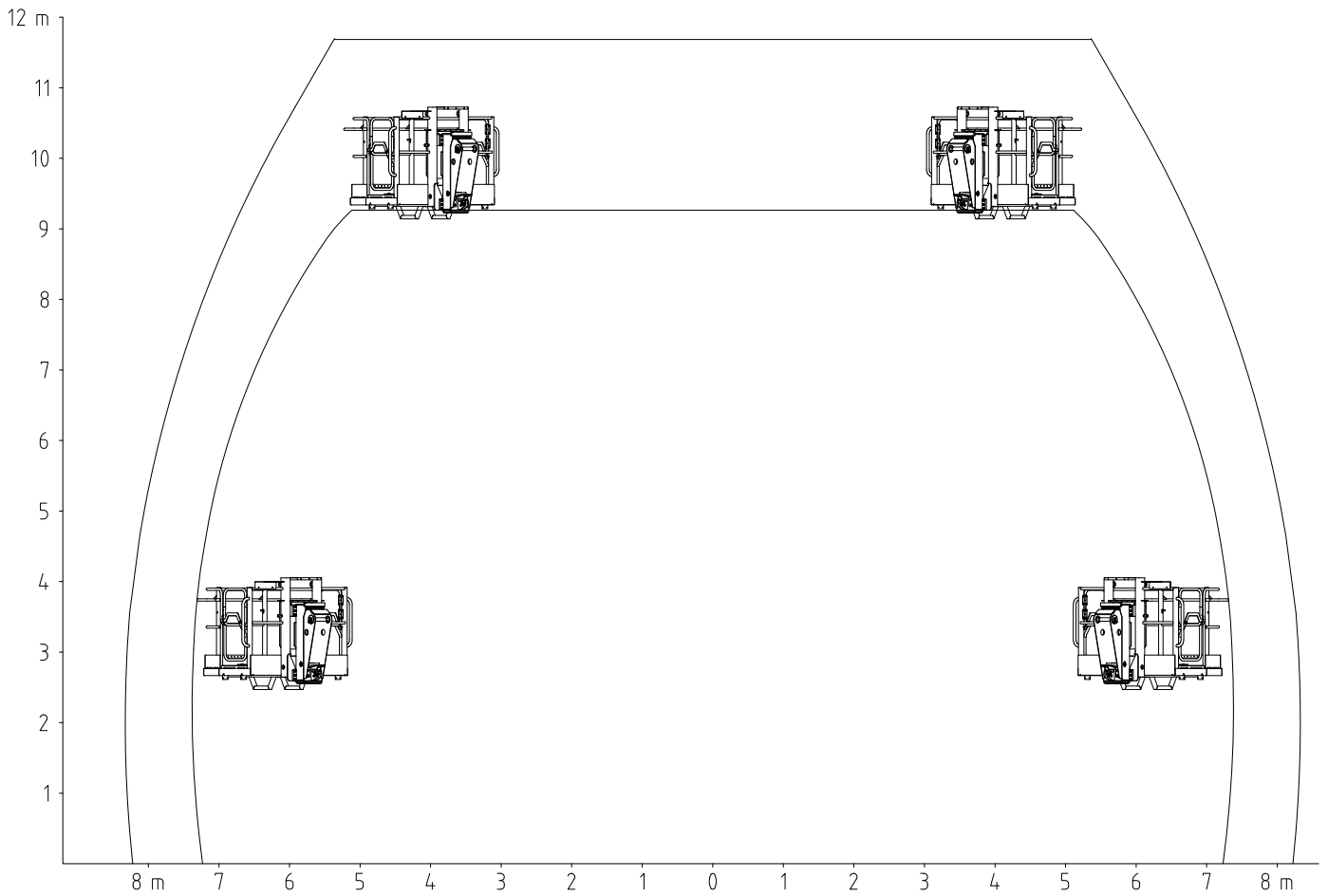

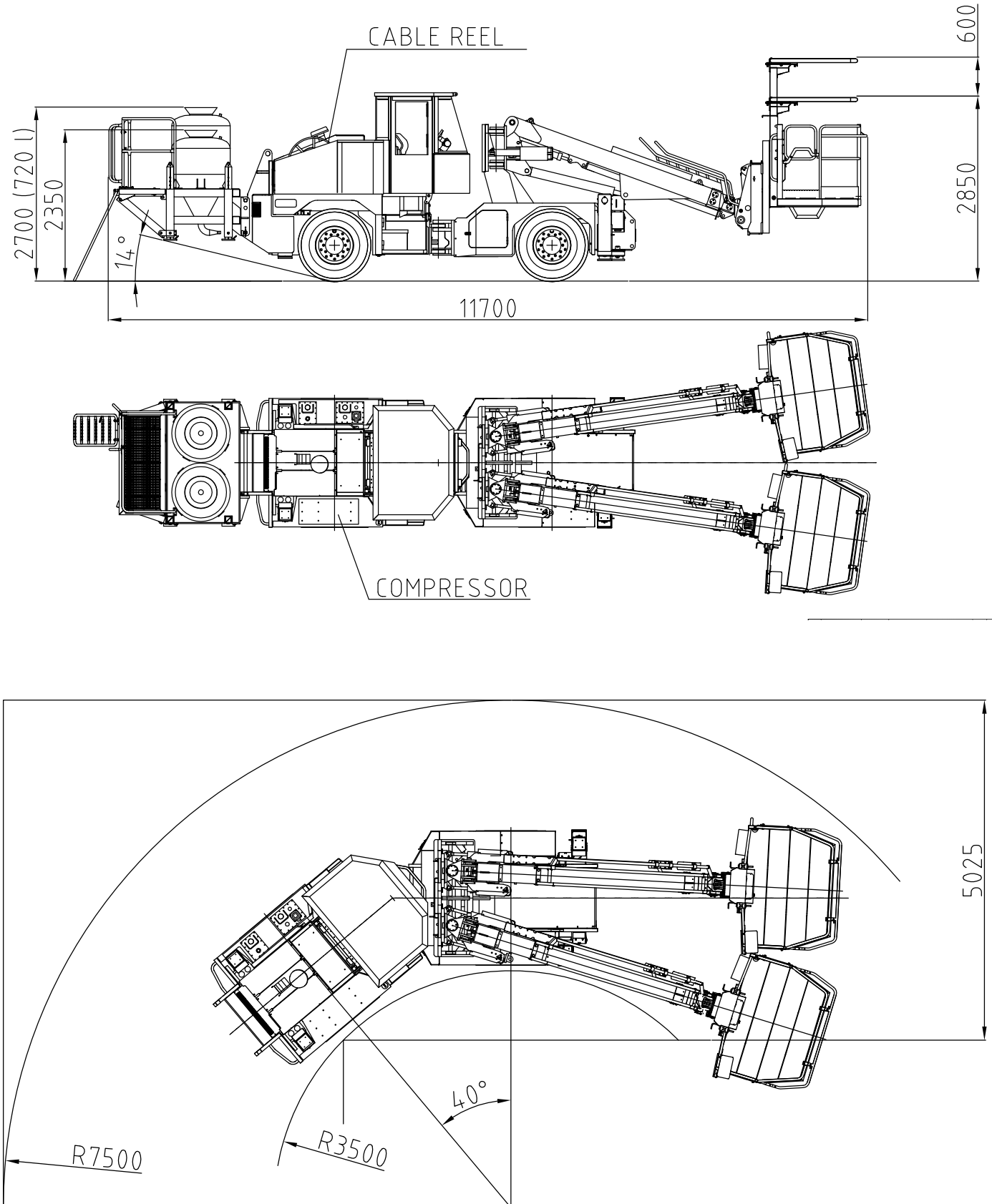
DIMENSIONS WITH OPTIONS

HIMEC 9905 BT

is a self propelled twin boom unit suitable for lifting and installing works and charging of explosives in tunnells.

DIMENSIONS

Length	9700 mm
Width	2050/3500 mm
Height	2900 mm
Wheel base	3350 mm
Ground clearance	310 mm
Outer turning radius	7500 mm
Inner turning radius	3600 mm
Weight, max. total	19600 kg

NORMET TWINBOOM NBB3

Twinboom is suitable for charging, bolting and installing works. Boom controls are in the basket and down on the carrier. Each boom can be operated independently allowing several holes to be charged safely at the same time. Large coverage allows the whole face to be charged from one setup.

Baskets can be equipped with FOPS tested safety canopy (EN ISO 3449).

Boom lift	- 20° ... + 60°
Boom slew	-8°/+40°
Max. platform height	9,5 m
Vertical working reach	11,6 m
Lateral working reach	16 m
Lifting capacity	500 kg = 2 pers. + 340 kg / basket

SUPPORT LEGS

One pair in front and one pair at rear, hydraulically operated, front pair with lateral extensions.

WORKING LIGHTS

On baskets	4 x 70 W
On carrier	4 x 70 W

SAFETY CANOPY

over the drivers seat fulfills the European safety regulations. Driver's cabin is FOPS/ROPS tested

CARRIER NC 98

is specially designed for underground use. Diesel engine with hydro-dynamic transmission and 4-wheel drive gives max. tractive effort of 85 kN and max. speed of 25 km/h. Fully enclosed multidisc 2-circuit brakes and parking and emergency brake make operating reliable and safe in the harsh underground conditions.

Diesel engine	96 kW
Max. tractive effort	85 kN
Max. speed	25 km/h

OPTIONAL EQUIPMENT:

Enclosed cabin for NC98 (ROPS/FOPS)
Particle filter for Deutz TCD 2012 L04 96kW
Xenon working lights on cabin (2 + 2) 35W
LED driving lights (4 + 2 pcs)
LED working lights on cabin (2 + 2 pcs)

ADDITIONAL EQUIPMENT:

Electro hydraulic drive 15kW:

- 400 V / 50 Hz with 50 m cable and hydr. reel
- 440 V / 50 Hz with 50 m cable hydr. reel
- 690 V / 50 Hz with 50 m cable hydr. reel
- 1000 V / 50 Hz with 50 m cable hydr. reel

Hydraulic driven high pressure washer 180 bar / 30 L
CD/Radio system (enclosed cabin)
Cabin heating (enclosed cabin)
Air conditioning (enclosed cabin)
Safety bar
Safety roof with hydraulic lift
Safety roof with hydraulic lift and slide
Fogmaker extinguishing system (manual)
Fogmaker extinguishing system (automatic)
Ansul extinguishing system (manual)
Ansul extinguishing system (automatic)
Tempus manually actuated (Non CE)
Lubrication system for carrier and NBB booms (Lincoln)
Hydraulically driven compressor 5 m³/min
1 extra hand held fire extinguisher (12 kg)
1 extra rotating beacon amber
1 extra rotating beacon red
1 extra rotating beacon blue
1 extra strobe light white
Toolbox and maintenance tools
2 pcs wheel chocks with brackets
Spare wheel
Rack for equipment and tools
Text labels in:
Fin / Por / GB / Swe / Rus / Nor / Ger / Fra / Spa / Ita

LTC SERVICES:**SPARE PARTS**

Spare parts package A: Available for 1000 h of use*. Include periodical service, most common wearing parts and most critical safety parts.

Spare parts package B: Available for 3000 h of use*. Include periodical service, most common wearing parts and most critical safety parts.

* Recommendations are based on average hours - can vary a lot depending on work site conditions.

TRAINING SERVICES

Available before delivery, at start up and after delivery

Product training:

Operation and Maintenance
NorSmart
Foundation of electrics, hydraulics and mechanics
Audit

Process training:

Concrete spraying
Charging
Process audit

AUDIT SERVICES

To improve performance of the machines
To improve the performance of your processes
To help improve the quality of maintenance operations

SERVICE CONTRACTS

Spare parts supply programmes
Scheduled inspection programmes
Supervision programmes
Periodic maintenance programmes
Machine usage programmes

LINK ONE

Link One electronic spare part manuals

WARRANTY SERVICES

Extended warranty