



## Features

Normet RBO is the transport vehicle designed specifically for underground management and equipment transportation.

It is truly the ultimate underground vehicle: as robust, safe and powerful as a hard core working machine and at same time at least as nimble and comfortable as any SUV.

## Technical specification

### GENERAL

Rectangular profile tube frame  
Corrosion protection  
Heavy duty bumpers front and rear  
Flexible protection shield on corners and sides  
1 tonne carrying capacity  
Container plywood lining

### ENGINE

Liquid cooled turbo charged Deutz TCD 2012 L4,  
96 kW/2200 rpm, TIER 3 certified

### EXHAUST SYSTEM

Catalytic exhaust gas purifier and muffler

### TRANSMISSION

Hydrostatic transmission, electronically controlled  
2 speed ranges  
Max speeds:

- Low range 30 km/h
- High range 50 km/h

Linde hydraulic pump and motor with drivethrough axle

### AXLES

Front: Dana 211 with wheel steering  
Rear: Dana 111  
On/off 100% differential lock at rear axle  
Full time 4WD

### TYRES

8.25 - 15 M857, 18 Ply

### BRAKES

**Service brake:** 2 circuit oil immersed multidisc brakes  
in both axles

**Safety/Parking brake:** hydraulically released fail-safe  
type brake in front axle

### SUSPENSION

Double parabolic leaf springs in front and at rear  
Heavy duty shock absorbers

### STEERING

Hydrostatic power steering.  
Orbitrol type

### FUEL TANK

Capacity 100 L

### HYDRAULICS

Hydraulic oil tank capacity 100 L  
Return oil filtration 10 µm  
190 bar, 44 l/min/2200 rpm

### ELECTRICAL SYSTEM

24 V negative ground electrical system  
Battery 2 x 110 Ah  
Alternator 80 A  
Driving halogen lights: dipped and main beams  
Reversing halogen lights 2x70 W  
Reversing alarm  
LED parking, brake and turning indicator lights  
Light rack behind cabin

- Working halogen lights 2x70 W
- Side lights (white/red)

### DRIVER'S COMPARTMENT

FOPS/ROPS  
Steering wheel on left hand side  
Seating for 5 persons  
Seat belts for all persons  
T-back front seats  
Lockable doors  
Laminated safety windscreen  
Rear view mirror, manual adjustment  
Windshield wipers  
Cabin heating and fresh air blower  
Gauges: speedo/hour meter, fuel, engine coolant  
temperature, tachometer, engine oil pressure,  
transmission oil temperature, transmission oil pressure  
Warning lights: common engine failure, parking brake  
pressure, transmission failure, engine coolant level,  
brake oil level, charging voltage, fuel water separator,  
air filter, hydraulic oil filter

### OTHER

Standard symbol labels  
12 kg hand held fire extinguisher

## Optional equipment

### ENGINE

Liquid cooled turbo charged Cat 4.4 ,  
96,5 kW/2200 rpm, TIER 3 approved

## LTC services

### SPARE PARTS

**Spare parts package A:** Available for 1000 h of use\*.  
Include periodical service, most common wearing parts  
and most critical safety parts.

**Spare parts package B:** Available for 3000 h of use\*.  
Include periodical service, most common wearing parts  
and most critical safety parts.

\* Recommendations are based on average  
hours - can vary a lot depending on work site conditions.

### TRAINING SERVICES

**Start-up training**  
**Customized training**

### AUDIT SERVICES

To improve performance of the machines  
To improve the performance of your processes  
To help improve the quality of maintenance operations

### SERVICE CONTRACTS

**Spare parts supply programmes**  
**Scheduled inspection programmes**  
**Supervision programmes**  
**Periodic maintenance programmes**  
**Machine usage programmes**

### LINK ONE

**Link One electronic spare part manuals**

### WARRANTY SERVICES

**Extended warranty**

## Additional equipment

### DRIVER'S CABIN

- Air conditioning
- Radio/CD player
- Back up camera and monitor
- Xenon head lights
- Steering wheel on right hand side

**Semiautomatic fire suppression system**

**Extra hand held fire extinguisher (12 kg)**

**Hydraulic oil by pass filtering system**

**Crane**

- Lifting capacity 8 kNm

**Lifter**

- Lifting capacity 250 kg
- Lifting height 2950 mm

**Extra hydraulic system**

**Hydraulic driven compressor**

- 0,4 m<sup>3</sup>/min/ 7 bar

**Hydraulic driven welding generator**

**Hydraulic driven generator**

**High pressure washer**

**Insulated exhaust pipe**

**Rod rack**

**Draw bar**

- D50 ball hook

**Draw bar**

**RUS hook**

**Extra gauge kit**

### LIGHT KIT ACCESSORIES

**Revolving warning lights:**

- Amber
- Red
- Blue
- Strobe light
- Search light (radio remote controlled)

### TYRE ACCESSORIES

**Spare wheel kit:**

- Spare wheel
- Wheel bracket
- 5 ton hydraulic jack
- Wheel nut wrench

### COLD CLIMATE ACCESSORIES

**Arctic kit:**

- Electric engine and interior heater
- Cold start system

## Dimensions

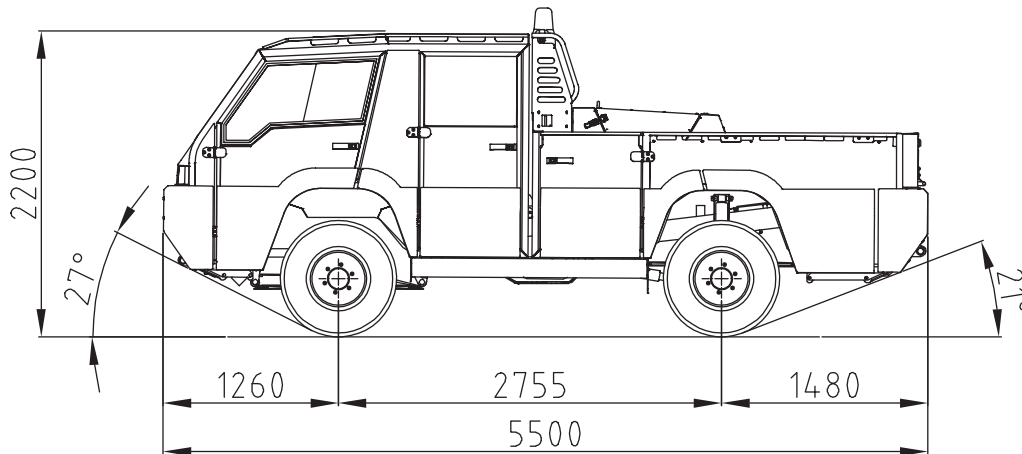

**SIDE VIEW**  
Basic RBO

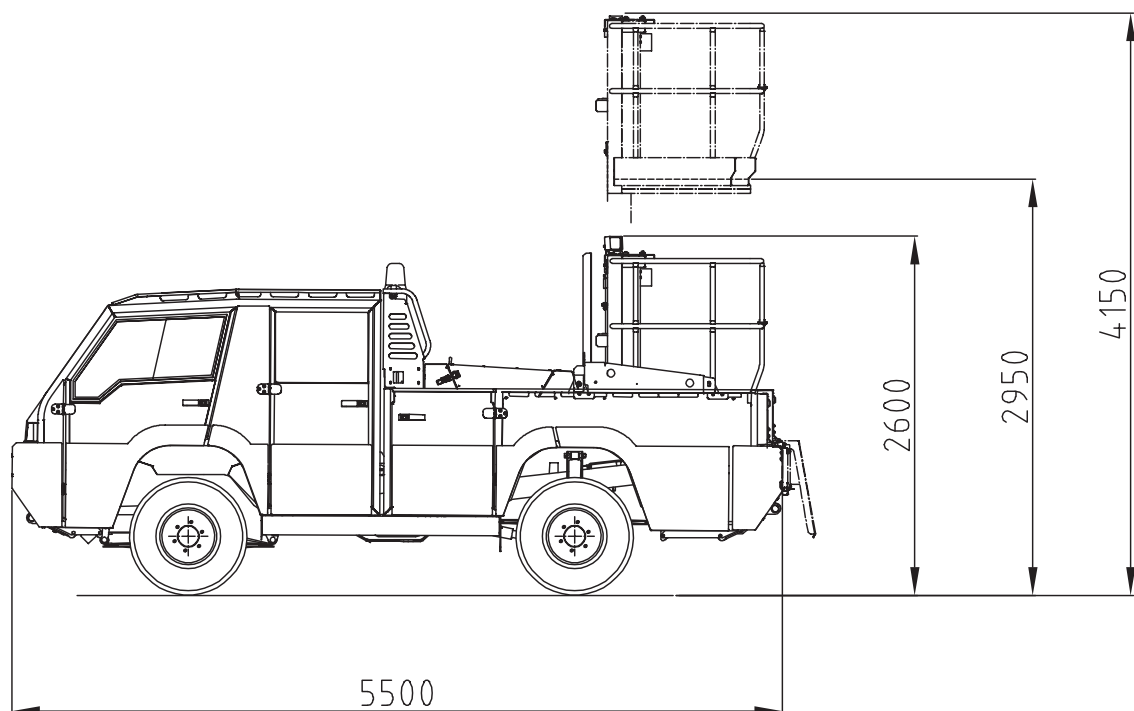

**SIDE VIEW**  
RBO with lifter

### DIMENSIONS

Length	5500 mm
Width	2000 mm
Height	2200 mm
Wheel base	2755 mm
Track	1720 mm
Ground clearance	260 mm

### TURNING RADIUS

Outer	6650 mm
Inner	3350 mm

### WEIGHT

Operating	4250 kg
Max. payload	1000 kg
Fully loaded	5250 kg

Normet reserves the right to change this specification without further notice.

**Dimensions**

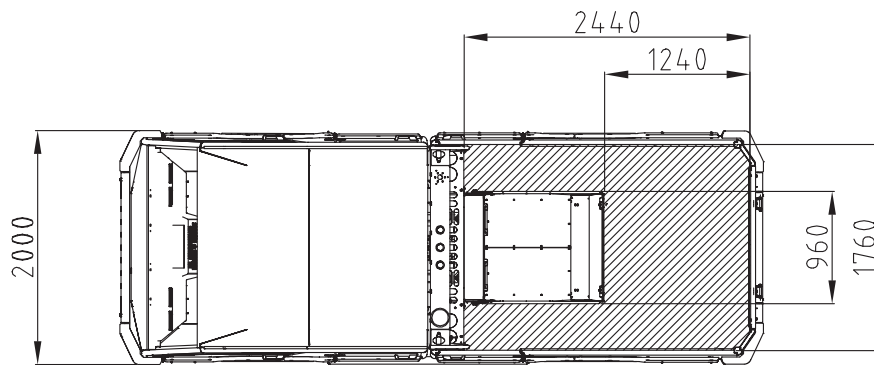

**TOP VIEW**

RBO with cargo bed dimensions

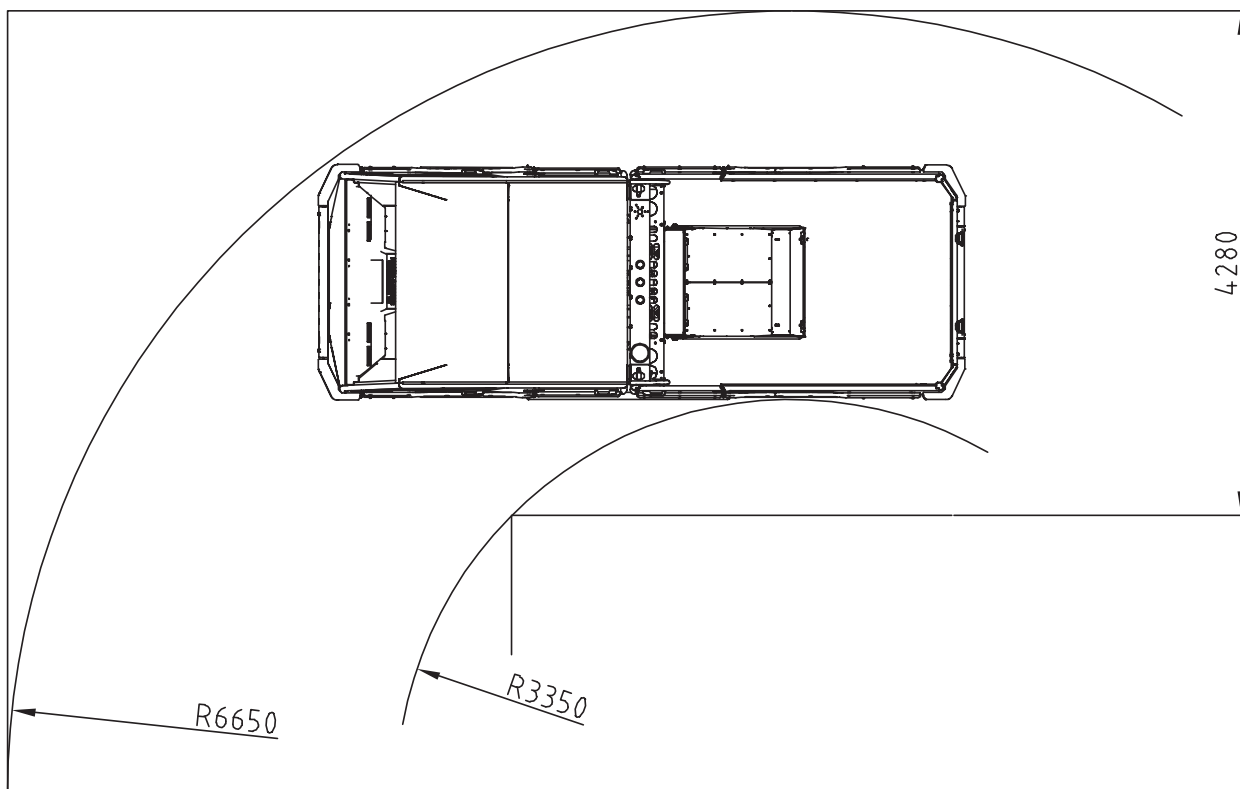

**TURNING RADIUS**

Normet reserves the right to change this specification without further notice.