

**normet**

Normet Oy  
Ahmolantie 6  
FI-74510 IISALMI, FINLAND  
Tel +358 (0) 17 83 241  
Fax +358 (0) 17 823 606  
info@normet.fi www.normet.fi

## Utimec 6160 Per

TI 1800018  
DATE 02.07.2012  
PAGE 1 / 4

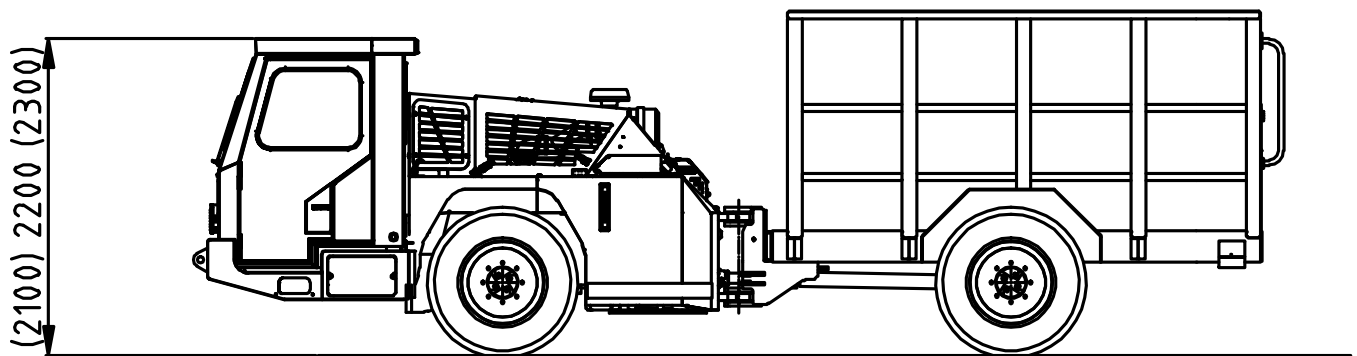
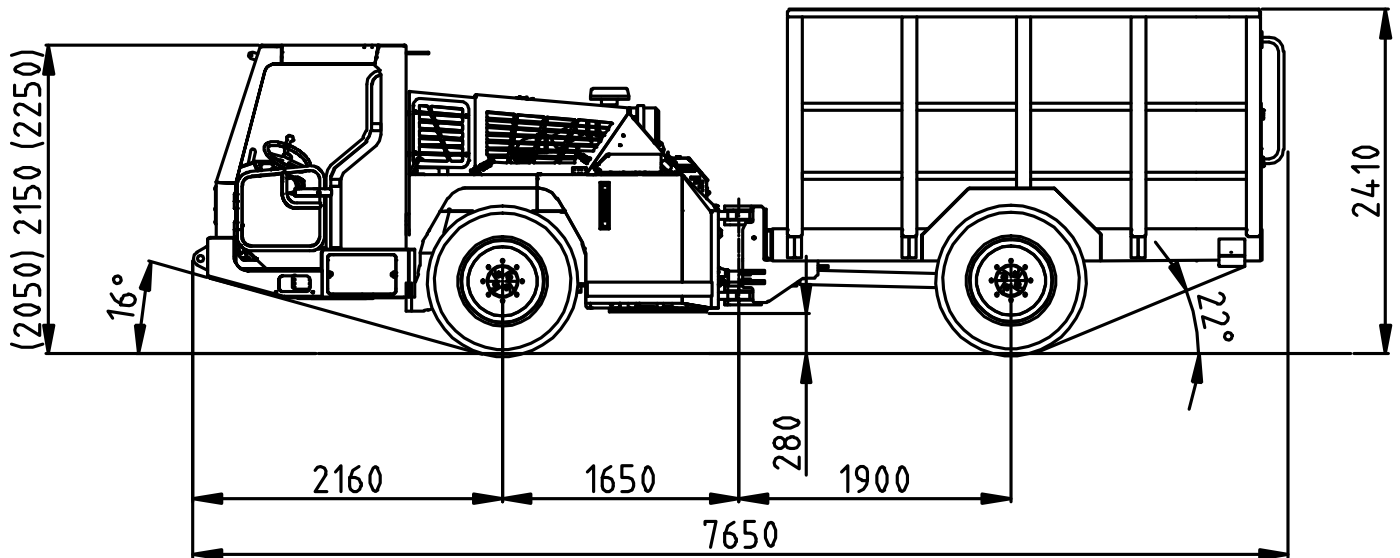

**normet**

Normet Oy  
Ahmolantie 6  
FI-74510 IISALMI, FINLAND  
Tel +358 (0) 17 83 241  
Fax +358 (0) 17 823 606  
info@normet.fi www.normet.fi

## Utimec 6160 Per

TI 1800018  
DATE 02.07.2012  
PAGE 2 / 4

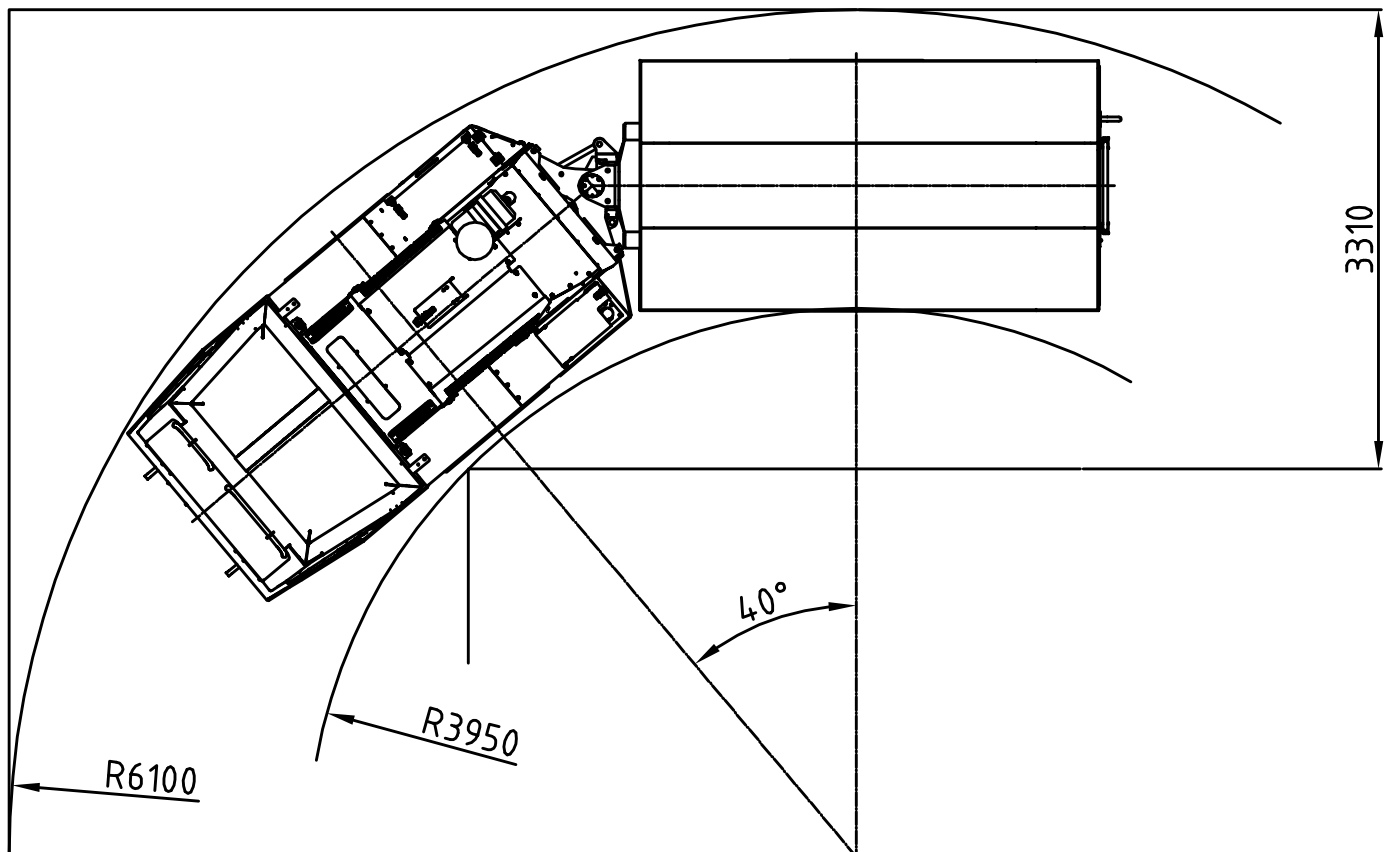
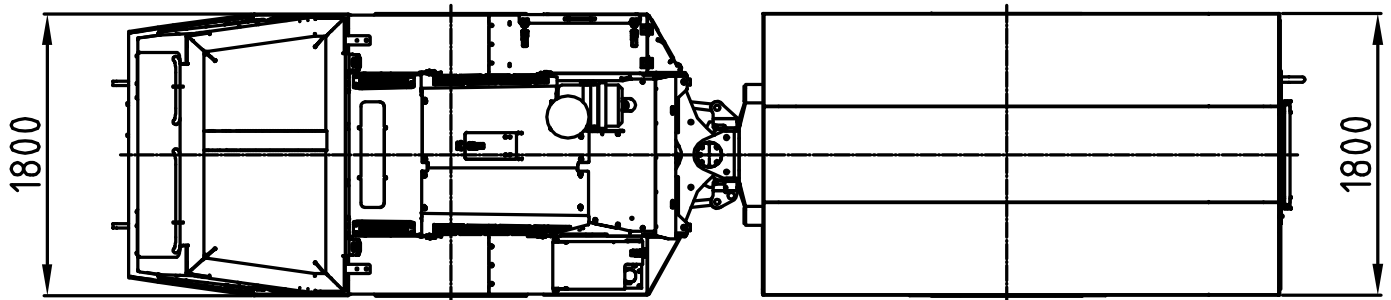

**DIMENSIONS**

Length	7650 mm
Width	1800 mm
Height	2410 mm
Wheel base	3550 mm
Track	1500 mm
Ground clearance	280 mm

**WEIGHT**

Operating	8000 kg
Max. payload	4000 kg

**TURNING RADIUS**

Outer	6100 mm
Inner	3950 mm

**PERS. COMPARTMENT**

Seats for 14 persons

**PERFORMANCE CURVE**

	<b>4800031</b>
1st gear	max. 5 km/h
2nd gear	12 km/h
3rd gear	25 km/h
Max. tractive effort	90 kN

**TRANSMISSION**Dana powershift  
3 speeds forward and reverse  
4-wheel drive**AXLES**Planetary type  
rear axle fixed  
front axle oscillation +/- 10°**TYRES**

10.00 - 20 PR 16

**BRAKES****Service brake:** hydraulically powered dual-circuit oil immersed multidisc brakes in both axles**Safety/Parking brake:** hydraulically released fail-safe -type brake**STEERING**Hydraulic frame steering,  
Orbitrol type  
Frame articulation +/- 40°**HYDRAULICS**190 bar, 95 l/min/2200 rpm  
for steering and brakes**ENGINE**Deutz TCD 2012 L4  
96 kW/2200 rpm**ELECTRICAL SYSTEM**24 V negative ground  
Battery 2 x 110 Ah  
Alternator 80 A  
Lights (2 + 2) x 70 W**DRIVER'S CABIN**

Open 2-man cabin FOPS/ROPS approved

**OPTIONAL EQUIPMENT:**

Enclosed cabin for NT60 (ROPS/FOPS)  
Mercedes-Benz OM 904 LA 90 kW engine  
Xenon working lights on cabin (2 + 2 pcs)  
LED driving lights (4 + 2 pcs)  
LED working lights on cabin (2 + 2 pcs)

**ADDITIONAL EQUIPMENT:**

CD/Radio system  
Cabin heating  
Air conditioning  
Fogmaker extinguishing system (manual)  
Fogmaker extinguishing system (automatic)  
Ansul extinguishing system (manual)  
Ansul extinguishing system (automatic)  
Tempus manually actuated (Non CE)  
Automatic lubrication system for carrier (Lincoln)  
Fast fuel filling system Wiggins  
1 extra hand held fire extinguisher (12 kg)  
1 extra rotating beacon amber  
1 extra rotating beacon red  
1 extra rotating beacon blue  
1 extra strobe light white  
Tools for maintenance  
Reversing camera  
NT60 spare wheel  
Text labels in:  
Fin / Por /GB / Swe / Rus / Nor / Ger / Fra / Spa / Ita

**LTC SERVICES****SPARE PARTS**

**Spare parts package A:** Available for 1000 h of use\*.  
Include periodical service, most common wearing parts  
and most critical safety parts.

**Spare parts package B:** Available for 3000 h of use\*.  
Include periodical service, most common wearing parts  
and most critical safety parts.

\* Recommendations are based on average  
hours - can vary a lot depending on work site  
conditions.

**TRAINING SERVICES**

Available before delivery, at start up and after  
delivery

**Product training:**

Operation and Maintenance  
NorSmart  
Foundation of electrics, hydraulics  
and mechanics  
Audit

**Process training:**

Concrete spraying  
Charging  
Process audit

**AUDIT SERVICES**

To improve performance of the machines  
To improve the performance of your processes  
To help improve the quality of maintenance operations

**SERVICE CONTRACTS**

Spare parts supply programmes  
Scheduled inspection programmes  
Supervision programmes  
Periodic maintenance programmes  
Machine usage programmes

**LINK ONE**

Link One electronic spare part manuals

**WARRANTY SERVICES**

Extended warranty