

Pictured machine may include options and additional equipment.

Features

Utimec MF 500 Transmixer with practical concrete transport capacity of 4.4 m³ is designed for concrete transportation in underground mines and tunnels where tramming height is 2.4 m (8.0 feet) or more.

The powerful liquid cooled turbo charged Deutz 120 kW, or MB 110 kW TIER 3 engine provides clean and efficient operation and gives maximum speed of 9 km/h fully loaded in upward inclined 1:7 tunnel. In horizontal tunnel the maximum speed is 25 km/h.

The standard drum lifter feature allows flexible adjustment of the concrete discharge height up to 1.9 m making it possible to discharge the load also in circumstances where receptive unit is not on the same angle or same level as the concrete transporter.

The FOPS and ROPS approved safety cabin provides superior visibility and comfortable compartment for the driver and his assistant. The enclosed cabin provides noise level < 75 dB. All daily checks can be done from the ground level.

Technical specification**CONCRETE DRUM**

Drum volume (100% fill) 5.5 m³
Transportation capacity 4.4 m³
Two filling hatches (round)
Aluminium rear hatch
Hydraulically controlled mixing and unloading
Adjustable rotating speed 0...13 rpm
Drum lift
Drum discharge height 1330 - 2000 mm
Manual drum lock
Drum control panel on left side

ENGINE

Liquid cooled turbo charged Deutz TCD 2013 L4,
120 kW/2300 rpm, TIER 3 approved

EXHAUST SYSTEM

Catalytic exhaust gas purifier and muffler

TRANSMISSION

Dana 24 000 series power shift with pump drive group
3 speeds forward and reverse
4-wheel drive

AXLES

Planetary type
Dana 123
Load end axle fixed
Engine end axle oscillation +/- 10°

TYRES

12.00 - 20 PR 20

PERFORMANCE

1st gear max.	6 km/h
2nd gear	12 km/h
3rd gear	25 km/h
Max. tractive effort	133 kN
Max speed in 1:7 inclined tunnel	
• Fully loaded	9 km/h
• Empty	11 km/h
Performance curve	100018584

BRAKES

Service brake: hydraulically powered dual-circuit oil immersed multidisc brakes in both axles
Safety/Parking brake: spring applied hydraulically released fail-safe -type brake. Brake testing possible from cabin

STEERING

Hydraulic frame steering
Orbitrol type
Frame articulation +/- 40°

FUEL TANK

Capacity 112 L

HYDRAULIC SYSTEM

Variable displacement pump system
190 bar, 95 L/min/2200 rpm
Hydraulic oil tank capacity 115 L
Return oil filtration 10 µm
Indication of level, filtration and temperature

24 VDC ELECTRICAL SYSTEM

Exposed components are min IP 65 standard
Battery 2 x 115 Ah
Alternator 100 A
Driving halogen lights (4 + 2 pcs) 70 W
Working halogen lights (2 + 2 pcs) 70 W
Working halogen lights on load end (2 pcs) 70 W
LED parking, brake and indicator lights
LED side lights; amber
Side reversing halogen lights 70 W
Rotating beacon; amber
Wire harness (self extinguishing) with tinned wires and water tight conduits

DRIVER'S COMPARTMENT

Open 2-man cabin FOPS/ROPS approved
Air suspended driver's seat
Seats with retractable lap seat belt
Forward and side seating for the driver with two sets of pedals (brake and accelerator)
CAN Cockpit, Master Gauge:

- Tacho, rpm
- Operating hours
- Fuel level
- Transmission temperature
- Cooling water temperature

GREASING SYSTEM

Centralized grease fittings for the carrier

OTHER

12 kg hand held fire extinguisher
Standard symbol labels

Optional equipment**FOR CONCRETE DRUM**

Hydraulic drum brake
Drum control panel on right side

DRIVER'S CABIN

Enclosed cabin
Air suspended T-back seat for driver and passenger

ENGINE

Liquid cooled turbo charged Mercedes-Benz OM 904
LA, 110 kW/2200 rpm, TIER 3 approved

1st gear max.	6 km/h
2nd gear	13 km/h
3rd gear	25 km/h
Max. tractive effort	120 kN
Max speed in 1:7 inclined tunnel:	
• Fully loaded	7 km/h
• Empty	12 km/h
Performance curve	4800030

EXHAUST SYSTEM

Particle filter for Deutz TCD 2013 L4 120 kW

OTHER

Xenon working lights on cabin (2 + 2 pcs) 35 W
Xenon working lights on load end (2 pcs) 35 W
LED driving lights (4 + 2 pcs) 18 W
LED working lights on cabin (2 + 2) 43 W
LED working lights on load end (2 pcs) 43 W
Warning lights, 1 unit:

- Rotating beacon; red
- Rotating beacon; blue

Additional equipment**FOR CONCRETE DRUM**

High pressure washer with tank
Form oil system with tank
280 L water/chemical stainless steel tank
Mixer bowl lifting lock

FOR ENCLOSED CABIN

CD/Radio system
Cabin ventilation:

- Cabin heating
- Air conditioning

FIRE SUPPRESSION SYSTEM

Fogmaker: Manually actuated
Fogmaker: Automatically actuated
Ansul: Manually actuated
Ansul: Automatically actuated
Tempus: Manually actuated (Non CE)

GREASING SYSTEM

Automatic lubrication system for carrier: Lincoln

AUXILIARY BRAKING SYSTEM

Electromagnetic retarder
Mounted in driveline
Recommended on inclines deeper than 1:10 and longer than 1000 m

OTHER

Fast fuel filling system: Wiggins
Extra hand held fire extinguisher (12 kg)
Warning lights, 1 unit:

- Rotating beacon; amber
- Rotating beacon; red
- Rotating beacon; blue
- Strobe light; white

Text labels in: Fin / Por / GB / Swe / Rus / Nor / Ger /
Fra / Spa / Ita

Toolbox and maintenance tools
2 wheel chocks with brackets
Reversing camera
Spare wheel

LTC services

SPARE PARTS

Spare parts package A: Available for 1000 h of use*.
Include periodical service, most common wearing parts and most critical safety parts.

Spare parts package B: Available for 3000 h of use*.
Include periodical service, most common wearing parts and most critical safety parts.

* Recommendations are based on average hours - can vary a lot depending on work site conditions.

TRAINING SERVICES

Available before delivery, at start up and after delivery

Product training:

Operation and Maintenance

NorSmart

Foundation of electrics, hydraulics and mechanics

Audit

Process training:

Concrete spraying

Charging

Process audit

AUDIT SERVICES

To improve performance of the machines

To improve the performance of your processes

To help improve the quality of maintenance operations

SERVICE CONTRACTS

Spare parts supply programmes

Scheduled inspection programmes

Supervision programmes

Periodic maintenance programmes

Machine usage programmes

LINK ONE

Link One electronic spare part manuals

WARRANTY SERVICES

Extended warranty

normet

Utimec MF 500 Transmixer

Technical data sheet

100018447

25.05.2012

Dimensions

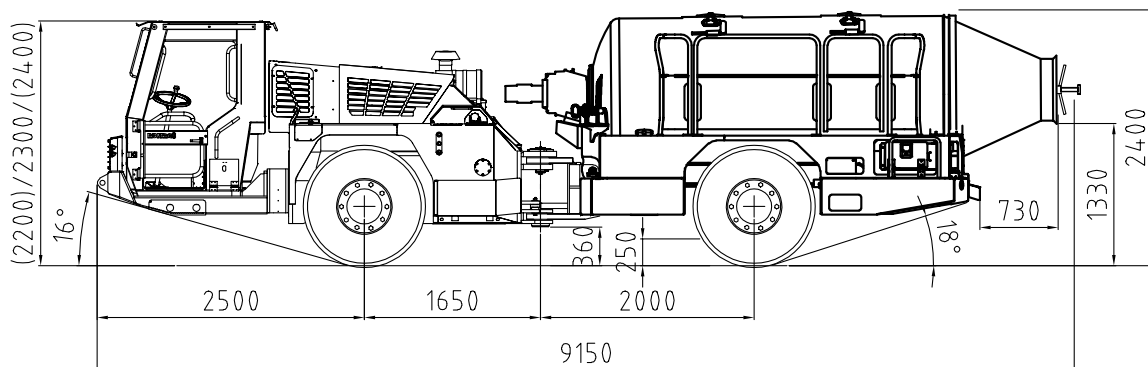

SIDE VIEW

Basic machine.

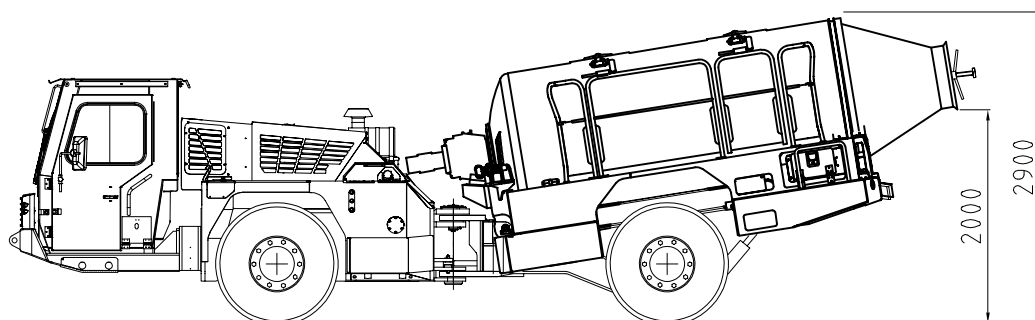

SIDE VIEW

Machine with enclosed cabin

DIMENSIONS

Length	9150 mm
Width	2000 mm
Height	2400 mm
Height of cabin	(+/- 100 mm) 2300 mm
Wheel base	3650 mm
Track	1650 mm
Ground clearance as shown	250 mm

TURNING RADIUS

Outer	6550 mm
Inner	3900 mm

WEIGHT

Operating weight:	
• Empty	12 000 kg
• Fully loaded	22 200 kg

Normet reserves the right to change this specification without further notice.

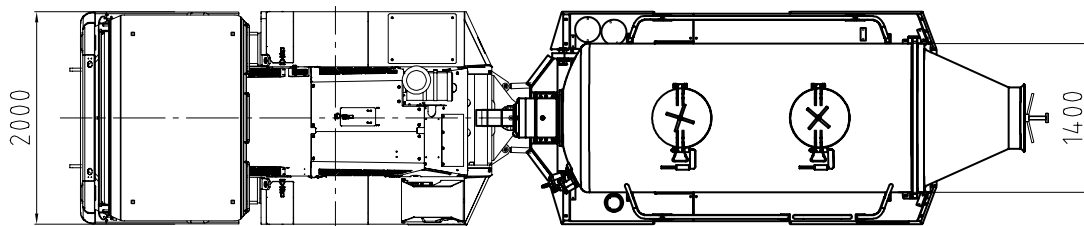
Dimensions**TOP VIEW**

Machine with options and extra equipment.

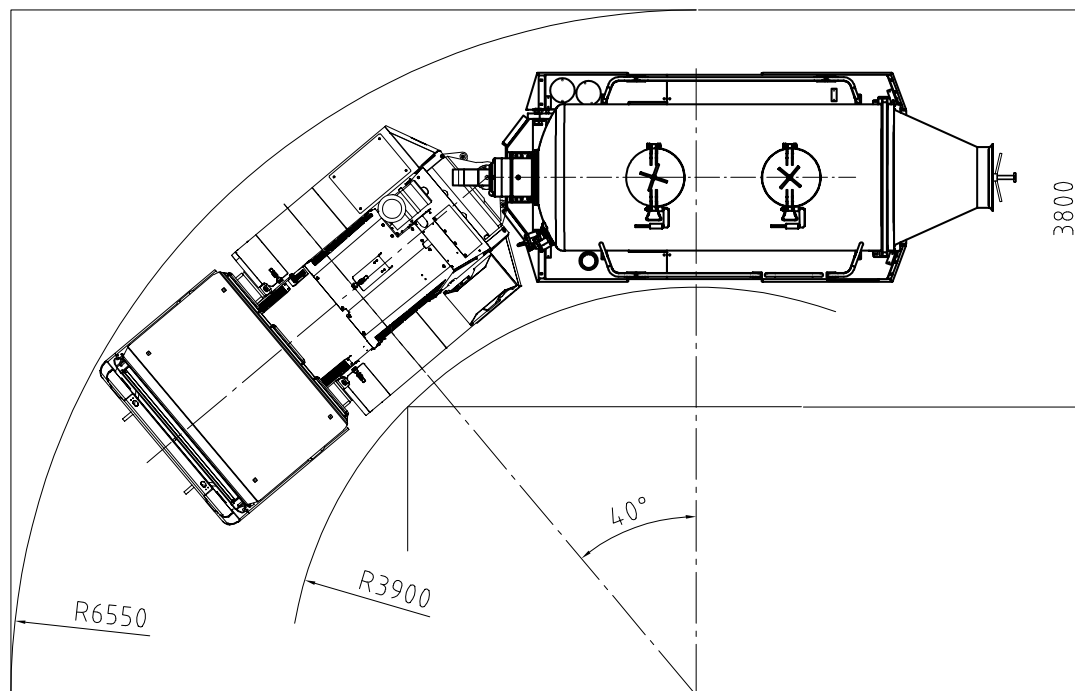
**TURNING RADIUS**

Normet reserves the right to change this specification without further notice.

Tractive efforts

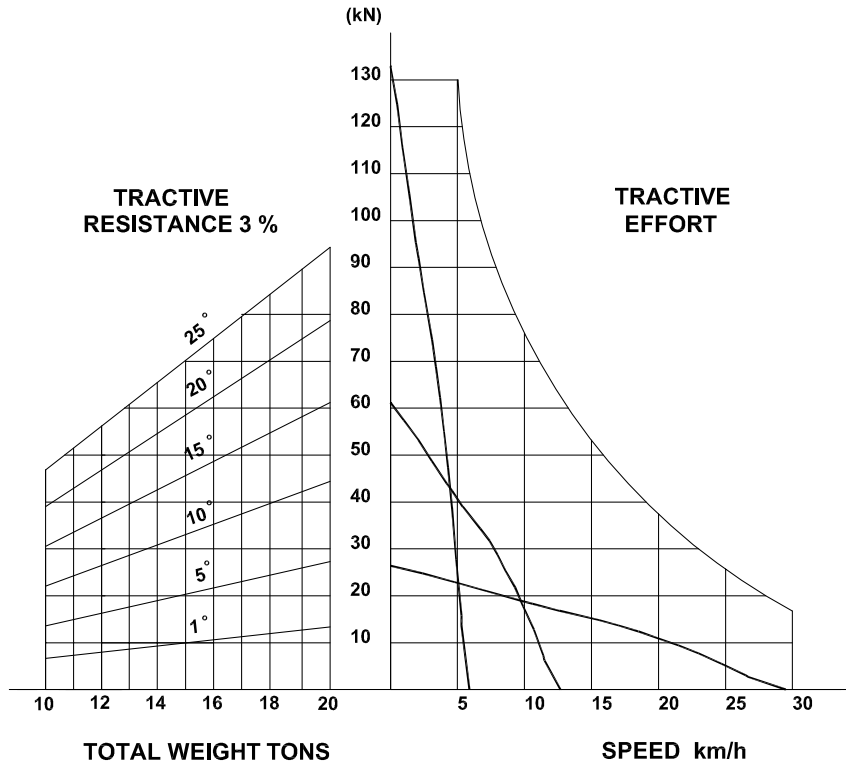

DEUTZ TCD 2013 L4 120 kW Performance curve 100018584

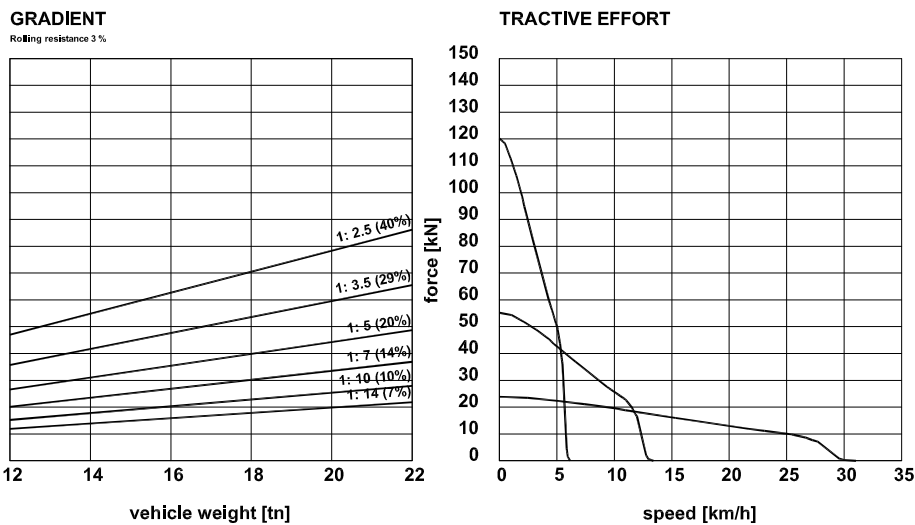

MERCEDES-BENZ OM 904 LA 110 kW Performance curve 4800030

Normet reserves the right to change this specification without further notice.